

4

3

2

1

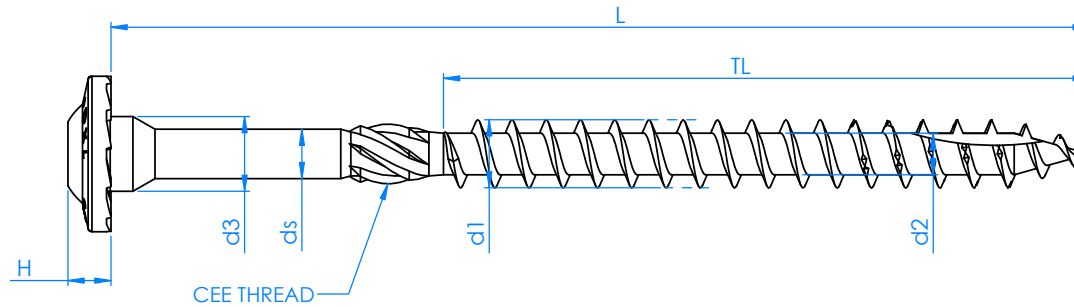
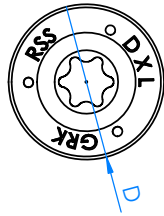

SIZE (DIA.)	NOMINAL LENGTH	LENGTH (L)	THREAD LENGTH (TL)	HEAD DIAMETER (D)	HEAD HEIGHT (H)	SHANK DIAMETER (ds)	MAJOR DIAMETER (d1)	MINOR DIAMETER (d2)	SHOULDER DIAMETER (d3)	STAR DRIVE SIZE
#10	2-1/2	2.50	1.57	0.453	0.100	0.142	0.193	0.124	0.224	T25
	3-1/8	3.12	1.61							
1/4	1-1/2	1.55	1.02	0.533	0.110	0.169	0.236	0.152	0.244	T25
	2	2.00	1.30							
	2-1/2	2.50	1.57							
	3-1/8	3.12	1.61							
	3-1/2	3.50	2.00							
5/16	2-1/2	2.50	1.57	0.620	0.157	0.195	0.276	0.167	0.301	T30
	2-3/4	2.75	1.81							
	3-1/8	3.12	1.61							
	3-1/2	3.50	2.00							
	4	3.96	2.60							
	5-1/8	5.12	3.39							
	6	5.87	3.94							
3/8	3-1/8	3.12	1.61	0.689	0.181	0.219	0.313	0.191	0.364	T40
	4	3.96	2.60							
	6	5.87	3.94							
	7-1/4	7.08	4.41							
	8	7.83	4.41							
	10	9.80	5.12							
	12	11.76	5.91							
	14-1/8	14.12	5.91							
16	15.70	5.91								

NOTES:

1. DIMENSIONS ARE IN INCHES
2. DIMENSIONS ARE NOMINAL VALUES, WITHOUT MANUFACTURING TOLERANCES
3. FASTENERS LESS THAN 2 IN. IN LENGTH DO NOT HAVE CEE THREAD FEATURE
4. SEE ICC-ES ESR-2442 FOR MORE TECHNICAL INFORMATION.

GRK
FASTENERS™

TITLE:
GRK RSS Drawing

PROPRIETARY AND CONFIDENTIAL
THE INFORMATION CONTAINED IN THIS
DRAWING IS THE SOLE PROPERTY OF
ILLINOIS TOOL WORKS, INC. ANY
REPRODUCTION IN PART OR AS A WHOLE
WITHOUT THE WRITTEN PERMISSION OF
ILLINOIS TOOL WORKS INC. IS PROHIBITED.

SIZE: **B** DRAWING DATE:
11/01/2023
SCALE 2:1 SHEET 1 OF 1

4

3

2

1